

# SHIN SHIN MARINE

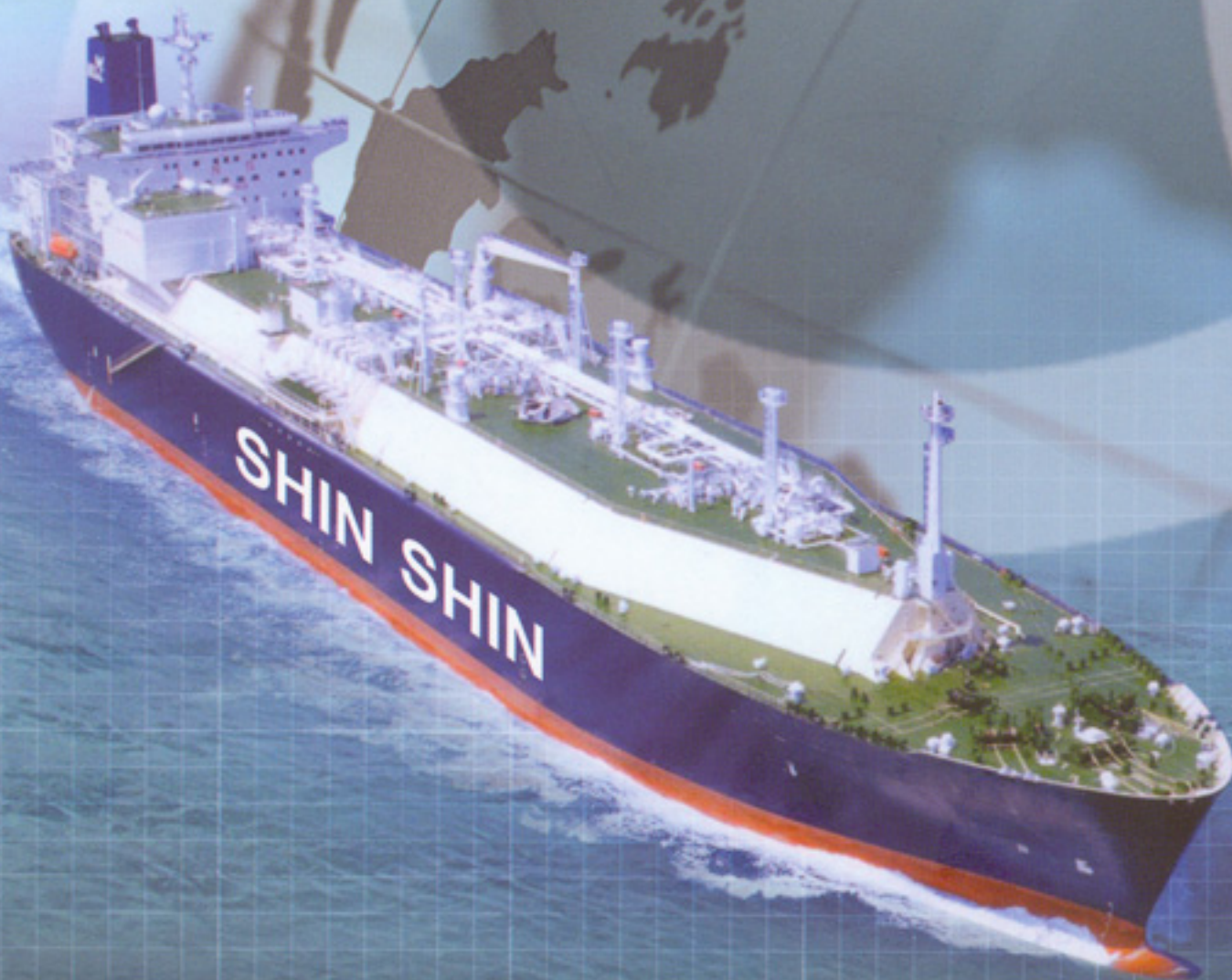

 SHIN SHIN MACHINERY CO., LTD.

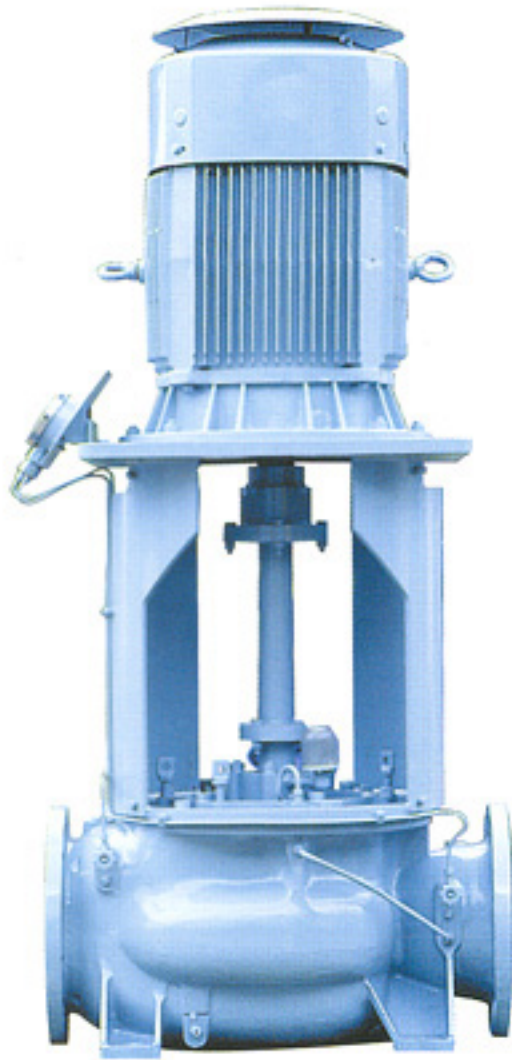



### ■ Applications

- Cooling sea water pump
- Cooling fresh water pump
- Ballast pump
- Inert gas cooling sea water pump
- C.O.P.T condenser cooling pump
- Others

### ■ Principal Particulars (Double Suction)

Item	Model	DB 250	DB 300	DB 350	DB 400	DB 500
Rotation		Clockwise viewed from driver end				
Suction bore (mm)		250	300	350	400	500
Discharge bore (mm)		250	300	350	400	500
Stuffing box seal		Grand packing or Mechanical seal				
Weight GC(BC) (kg)		403(420)	506(530)	803(845)	1124(1180)	2200(2310)
Water filled in casing (kg)		80	115	200	280	445

### ■ Standard Materials

Part No.	Name Of Part	REQ. NO. FOR 1PUMP	For Fresh Water		For Sea Water	
			Name	KS	Name	KS
1	CASING	1	CAST IRON	GC200	BRONZE	BC6
2	TOP COVER	1	CAST IRON	GC200	BRONZE	BC6
3A	'O' RING - UPPER	1	NBR		NBR	
3B	'O' RING - LOWER	1	NBR		NBR	
8	DOWEL	2	CARBON STEEL	SM45C	CARBON STEEL	SM45C
12	IMPELLER	1	PHOSPHORE BRONZE	PBC2	PHOSPHORE BRONZE	PBC2
14	WEAR RING-CASING	2	LEADED TIN BRONZE	LBC4	LEADED TIN BRONZE	LBC4
15	WEAR RING-IMPELLER	2	PHOSPHORE BRONZE	PBC2	PHOSPHORE BRONZE	PBC2
16	SET SCREW	6	STAINLESS STEEL	STS304	STAINLESS STEEL	STS304
17	SET SCREW - IMPELLER RETAINING	1	STAINLESS STEEL	STS304	STAINLESS STEEL	STS304
19	GLAND	1	BRONZE	BC6	BRONZE	BC6
20	GLAND PACKING	1	LUBRICATED COTTON		LUBRICATED COTTON	
30	RETAINING WASHER	1	STAINLESS STEEL	STS304	STAINLESS STEEL	STS304
31	LOCK WASHER	1	STAINLESS STEEL		STAINLESS STEEL	STS304
33	KEY	1	STAINLESS STEEL	STS304	STAINLESS STEEL	STS304
34	BEARING BUSH	1	PGA		PGA	
47	SHAFT	1	STAINLESS STEEL	STS304	STAINLESS STEEL	STS304
49	COUPLING SPACER	1	DUCTILE CAST IRON	GCD45	DUCTILE CAST IRON	GCD45
50	COUPLING BOLT	7	CR.MO STEEL	SCM440	CR.MO STEEL	SCM440
51	NUT - SELF LOCKING	7	CARBON STEEL	SM45C	CARBON STEEL	SM45C
58	MOTOR SUPPORT	1	STEEL	SS41	STEEL	SS41
59	MOTOR COUPLING	1	DUCTILE CAST IRON	GCD45	DUCTILE CAST IRON	GCD45
60	RETAINING WASHER	1	STEEL	SS41	STEEL	SS41
61	MOTOR COUPLING FASTENER	1	CARBON STEEL	SM45C	CARBON STEEL	SM45C
62	REAR GUARD	1	STEEL	SS41	STEEL	SS41
63	FRONT GUARD	1	STEEL	SS41	STEEL	SS41
252	LOCATION PIN	1	STAINLESS STEEL	STS304	STAINLESS STEEL	STS304
341	STOP RING	1	STAINLESS STEEL	STS304	STAINLESS STEEL	STS304

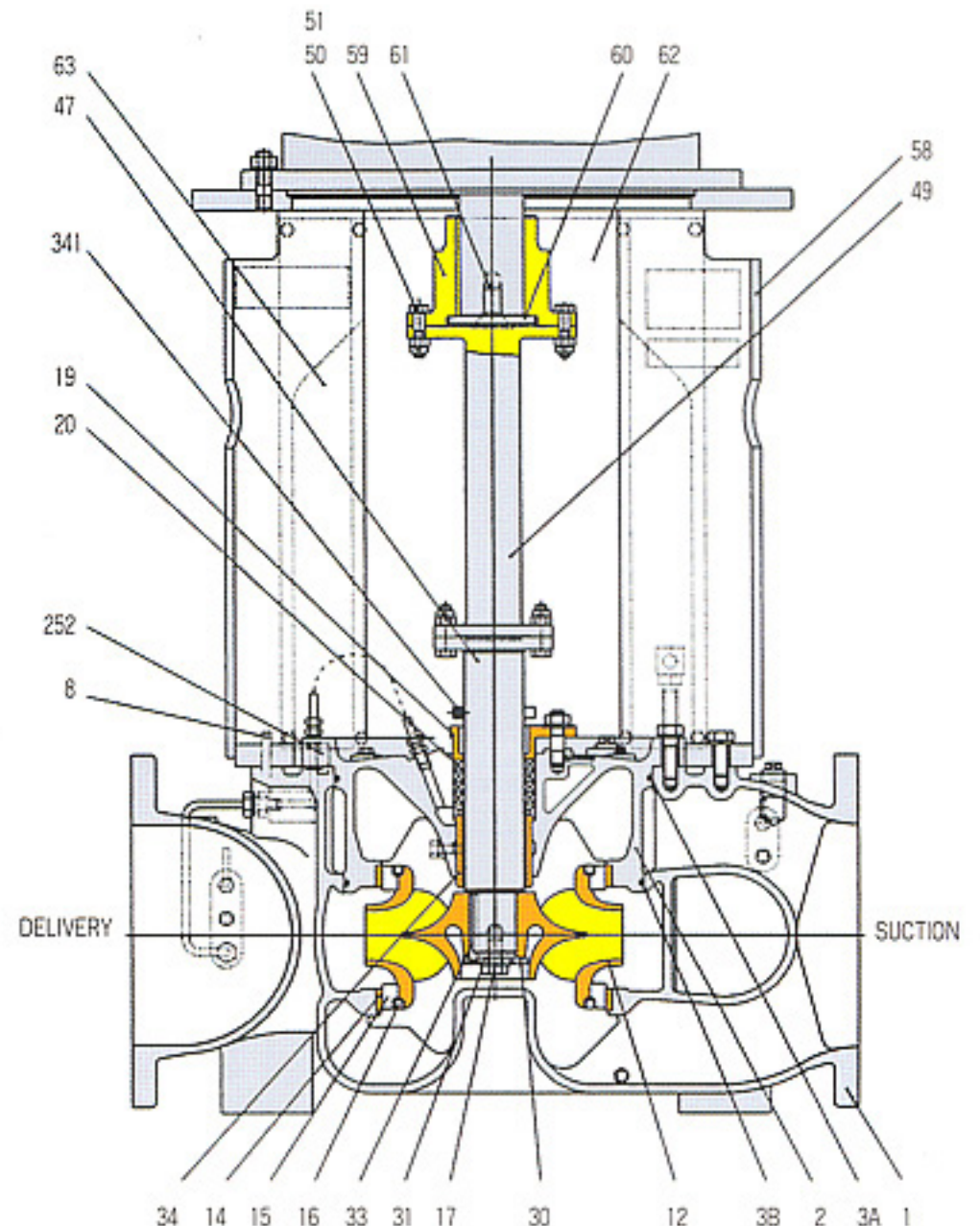



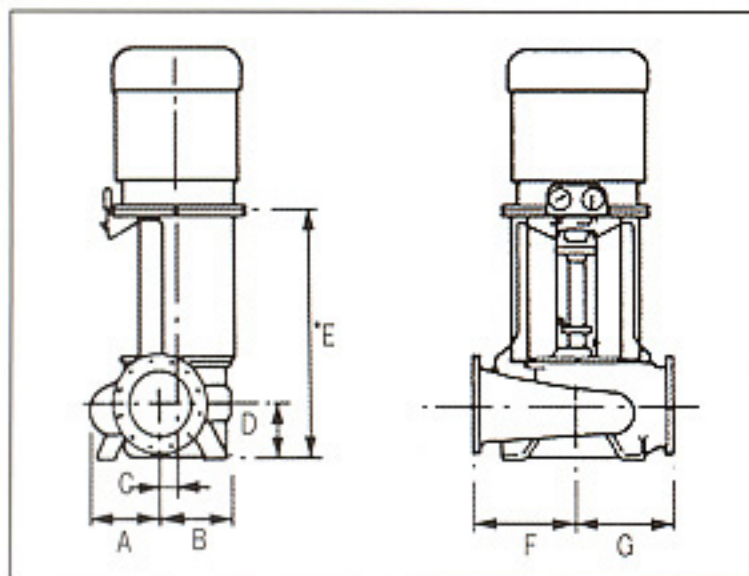
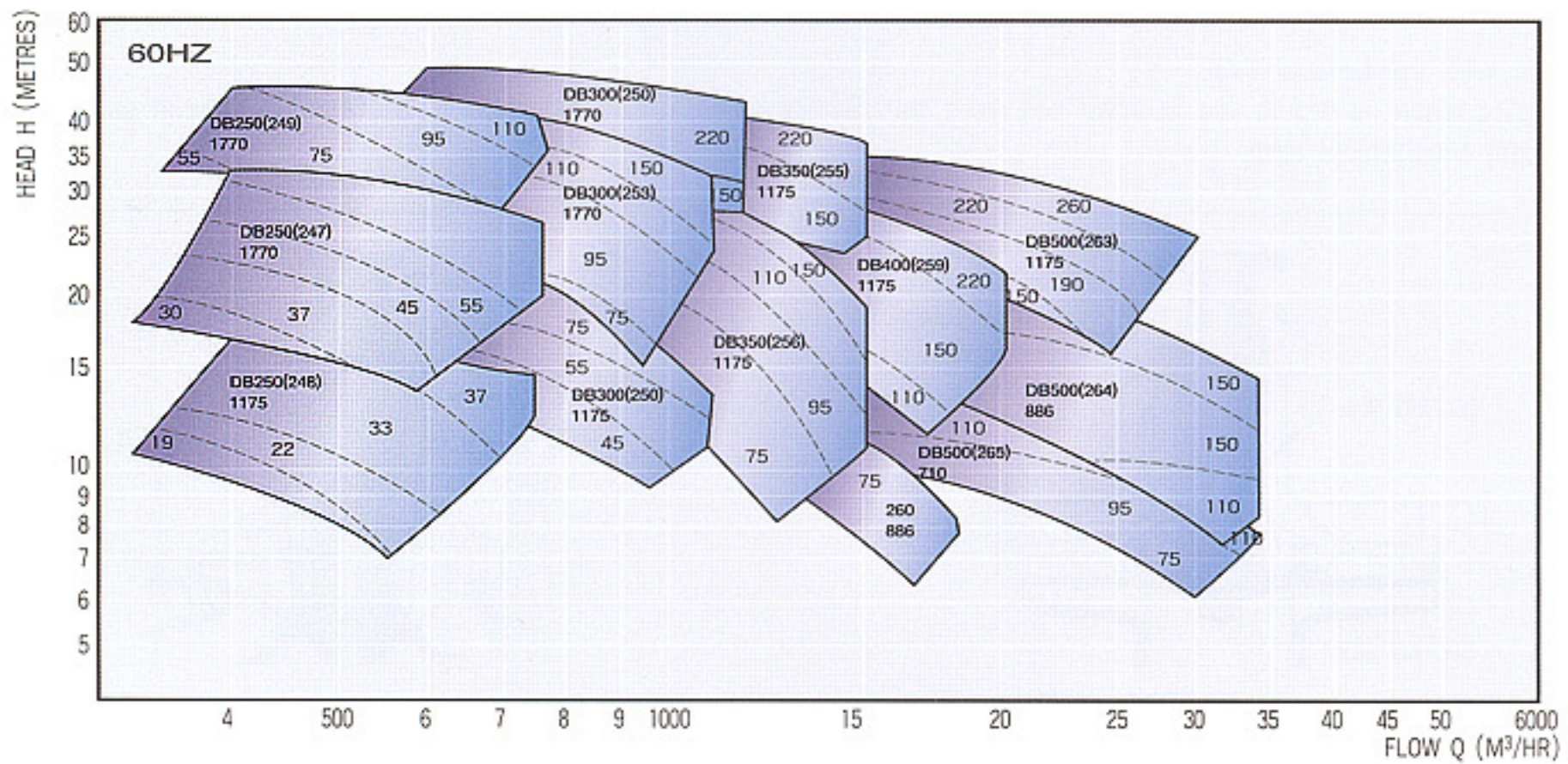
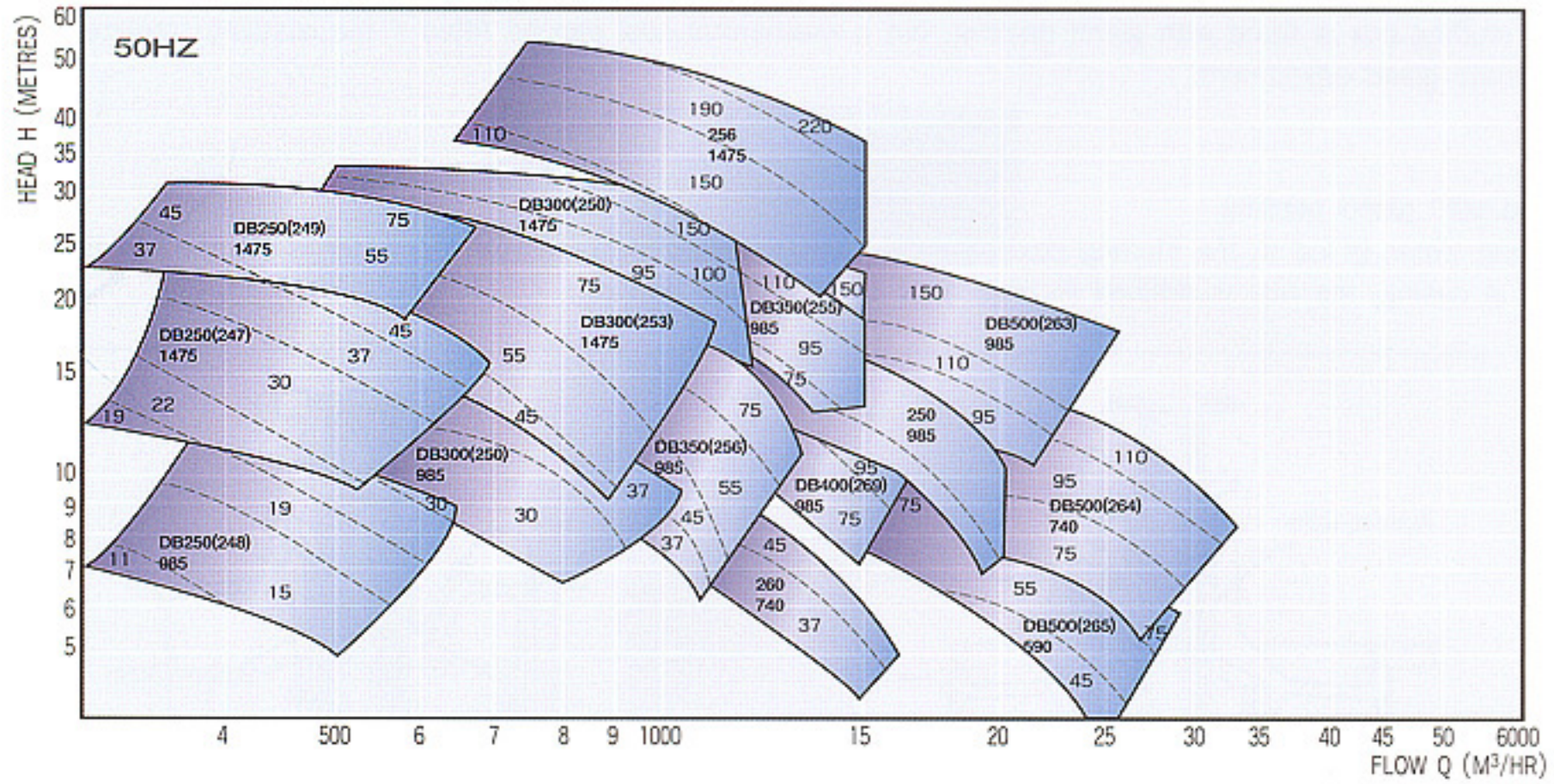

■ Dimensions For Double Suction Pumps

Part No. Type	Dimensions (mm)							
	A	B	C	D	E	F	G	H
DB250	330	320	38	200	1030	400	400	10
DB300	327	320	70	250	1124	450	450	22
DB350	390	440	80	260	1323	520	520	30
DB400	489	450	50	290	1420	570	570	35
DB500	690	610	102	394	1654	800	900	38



## ■ Stuffing Box Seal

The stuffing box is fitted with gland packing, but a mechanical seal can be fitted if the customer requires it to eliminate gland adjustment.

### Fitted with gland packing

Sealing water is led to the stuffing box from the discharge side, and most of the water is returned to the suction side in casing, the rest is drained to bilge after sealing gland packing.

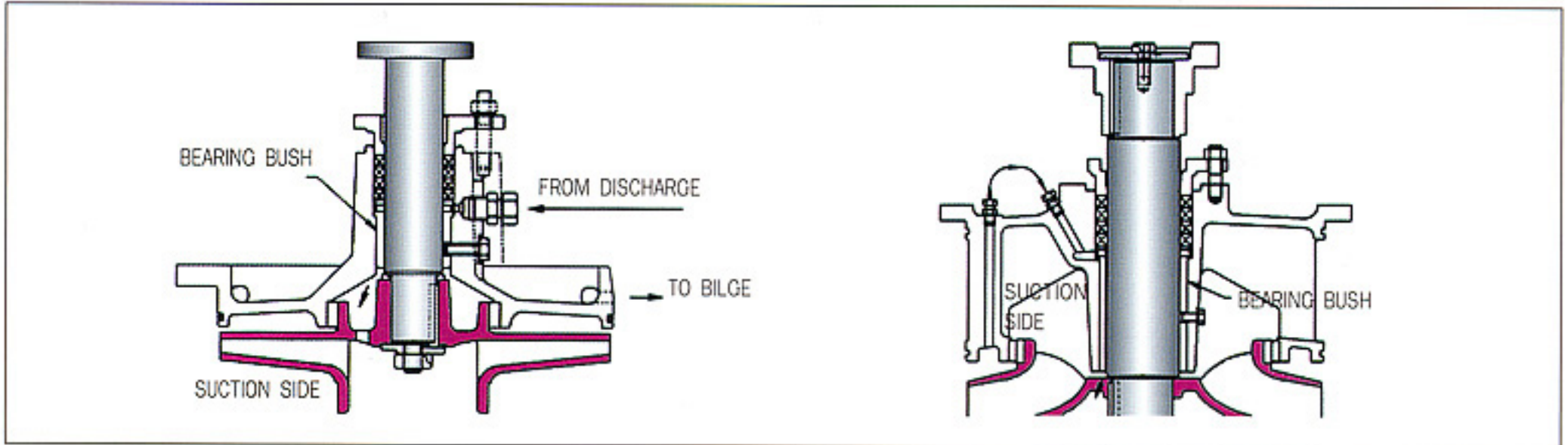

### Fitted with mechanical seal

Flushing water is led to the stuffing box from the discharge side, and returned to the suction side in casing after flushing mechanical seal.

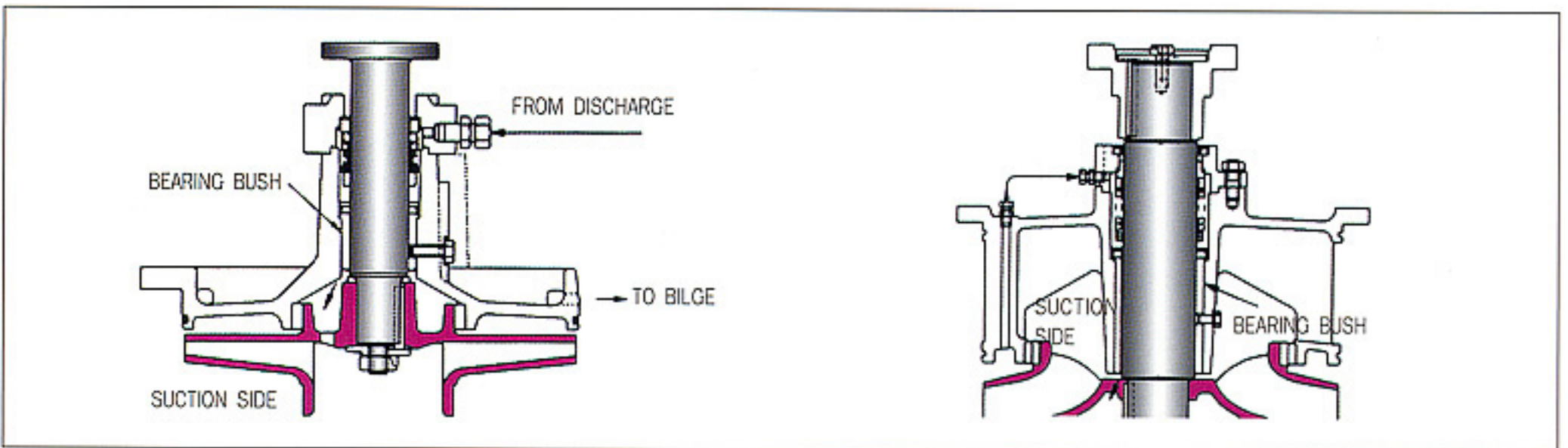

## ■ Priming Unit

When self priming is required, Air Ejector Primer or Liquid Ring Primer (LRP) is available. Liquid Ring Primer can be driven by belt connected with main pump shaft or a separately mounted motor. A guidance for selection of primer is as follows.

Item	Pump Model	B/C60	B/C/D125	B/C200	DB250	DB300	DB350	DB400	DB500
Air Ejector Primer	KAE I,II	○	○	○	○	○	○	○	○
Liquid Ring Primer driven by pump shaft	LRP50B	○	○	○	○				
Liquid Ring Primer driven by separate motor	LRP50M/100M	○	○	○	○	○	○	○	○

\* For the detail description of each primer, refer to the primer leaflet.

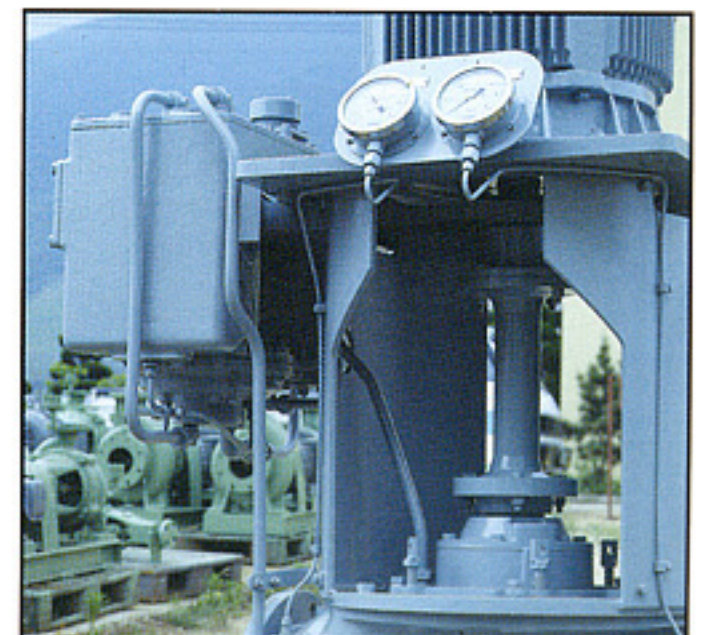



■ **Motor**

The motor for this type of pump must satisfy the following conditions:

**Axial thrust**

The thrust due to the weight of the rotating element acts downward.  
The maximum values are as shown in the following table.

Model	VID											
	B80	C80	B125	C125	D125	B200	C200	DB250	DB300	DB350	DB400	DB500
Thrust	34	38	49	58	52	70	83	50	80	100	-	-

Unit:Kg

**Notes**

- The thrust for DB400/500 pumps are variable according to the hydraulic force acting on the impeller.
- The thrust bearing for the motor must be of the fixed type(below 0.7mm) for up and down directions.
- The permissible value of elongation of the shaft end due to thermal expansion is to be less than 1mm.

**Screw at the motor shaft end**

(Bolt for fixing is supplied by Shin Shin)

In order to support the pump rotating element the shaft end must be provided with threaded hole for fitting the motor coupling.

**Rectangularity and eccentricity for motor flange**

The rectangularity of the flange face relative to the axis and the eccentricity of the flange fitting outside diameter must be less than 0.127mm when read from a dial indicator.

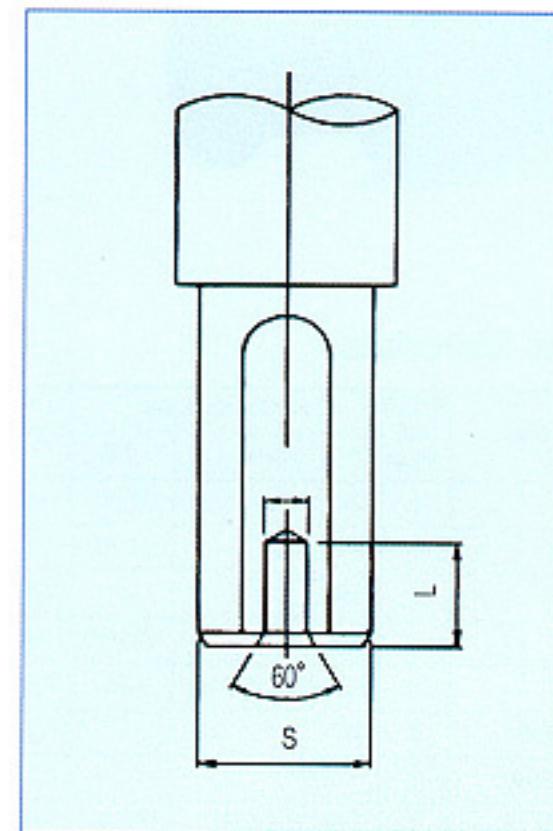

**Shaft end deflection**

The shaft end deflection must be less than 0.05mm when read from a dial indicator.

Motor Shaft(S)	D	Lmin
~38(7.5KW)	M12	22
~48(22KW)	M16	22
~85(150KW)	M16	22

Unit:mm

■ **Standard Accessories**

Discharge pressure gauge	1
Suction compound gauge	1
Gauge board	1
Gauge root valve	2
Sealing pipe	1 set
Vacuum unit(for self priming pump)	1 set

■ **Standard Spare Parts**

- 1 pump set of the following spare is supplied for 1ship.
- Gland packing or mechanical seal
  - Coupling bolt & nut
  - Bearing bush
  - Complete set of rotating element(if required)





Homepage : <http://www.sspump.com>

E-mail : [sales@sspump.com](mailto:sales@sspump.com)

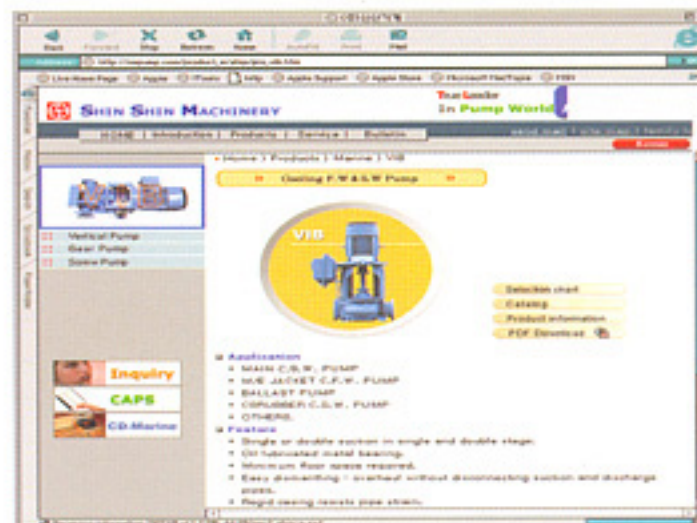

## SHIN SHIN MACHINERY CO., LTD.

### Head Office & Factory

940-13 Yerim-ri, Chongwan-Myen, Gijang-Gun, Pusan, Korea.

Phone : (051) 727-5300~4

Telefax: (051) 727-5305~8

### Seoul Office

Phone : +82-2-752-8419/8403, 778-8832

Telefax: -82-2-755-3156