

SHIN SHIN MARINE

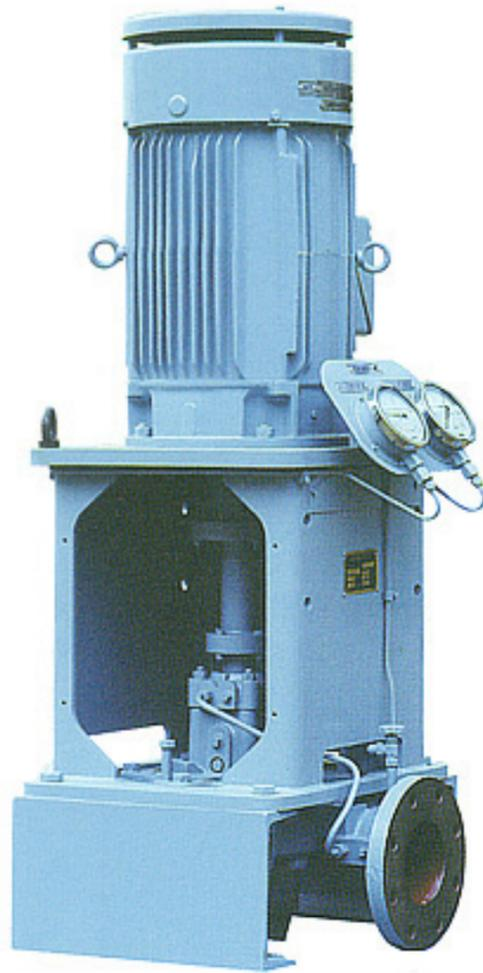

 SHIN SHIN MACHINERY CO., LTD.



■ Applications

- Piston cooling fresh water pump
- Jacket cooling fresh water pump
- Sea water service pump
- Ballast pump
- Others

■ Principal Particulars (Single Suction)

Item	Model	B80	C80	B125	C125	D125	B200	C200
Rotation		Clockwise viewed from driver end						
Suction bore (mm)		80	80	125	125	125	200	200
Discharge bore (mm)		80	80	125	125	100	200	200
Stuffing box seal		Grand packing or Mechanical seal						
Weight GC(BC) (kg)		230(243)	263(278)	258(276)	301(323)	359(388)	364(396)	364(396)
Water filled in casing (kg)		7	9	13	15	17	30	34

■ Standard Materials

Part No.	Name Of Part	REQ. NO FOR 1PUMP	For Fresh Water		For Sea Water	
			Name	KS	Name	KS
1	PUMP CASING	1	CAST IRON	GC200	BRONZE	BC6
2	INNER COVER	1	CAST IRON	GC200	BRONZE	BC6
3	'O' RING	1	NBR		NBR	
8	DOWEL	1	CARBON STEEL	SM45C	CARBON STEEL	SM45C
12	IMPELLER	3	PHOSPHORE BRONZE	PBC2	PHOSPHORE BRONZE	PBC2
13	CASE WEAR RING	1	PSG		PSG	
21	MECHANICAL SEAL	2				
22	SPRING SLEEVE	1	STAINLESS STEEL	STS304	STAINLESS STEEL	STS304
30	IMPELLER RETAINING WASHER	1	STAINLESS STEEL	STS304	STAINLESS STEEL	STS304
31	LOCK WASHER	1	STAINLESS STEEL	STS304	STAINLESS STEEL	STS304
32	IMPELLER RETAINING WASHER	1	STAINLESS STEEL	STS304	STAINLESS STEEL	STS304
33	IMPELLER KEY	1	STAINLESS STEEL	STS304	STAINLESS STEEL	STS304
37	OIL HOUSING	1	CAST IRON	GC200	CAST IRON	GC200
38	BEARING BUSH	1	LEADED TIN BRONZE	LBC4	LEADED TIN BRONZE	LBC4
39	OIL HOUSING COVER	1	CAST IRON	GC200	CAST IRON	GC200
42	JOINT	1	FIBRE		FIBRE	
47	PUMP SHAFT	1	STAINLESS STEEL	STS304	STAINLESS STEEL	STS304
49	COUPLING SPACER	1	DUCTILE CAST	GCD45	DUCTILE CAST IRON	GCD45
50	COUPLING BOLT	8	CR.MO STEEL	SCM440	CR.MO STEEL	SCM440
51	STIFF NUT	8	CARBON STEEL	SM45C	CARBON STEEL	SM45C
58	MOTOR SUPPORT	1	STEEL	SS41	STEEL	SS41
59	MOTOR COUPLING	1	DUCTILE CAST IRON	OCD45	DUCTILE CAST IRON	OCD45
60	MOTOR COUPLING WASHER	1	STEEL	SS41	STEEL	SS41
61	RETAINING SCREW	1	CARBON STEEL	SM45C	CARBON STEEL	SM45C
62	REAR GUARD	1	STEEL	SS41	STEEL	SS41
63	FRONT GUARD	1	STEEL	SS41	STEEL	SS41
164	'O' RING	1	NBR		NBR	

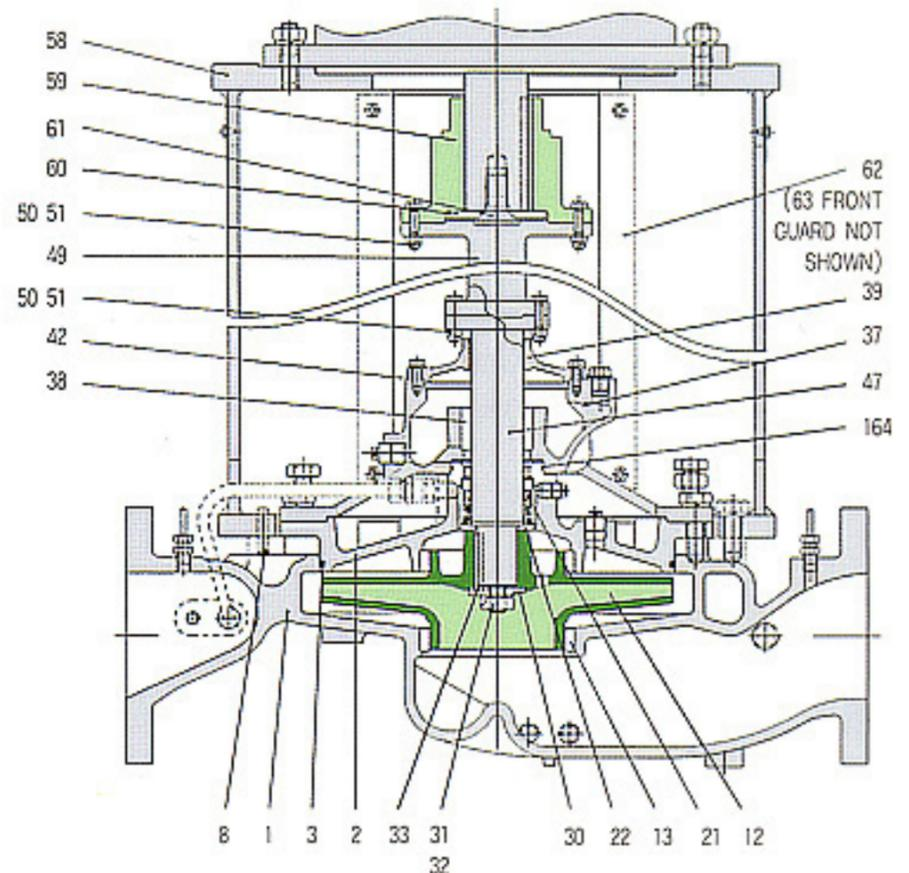

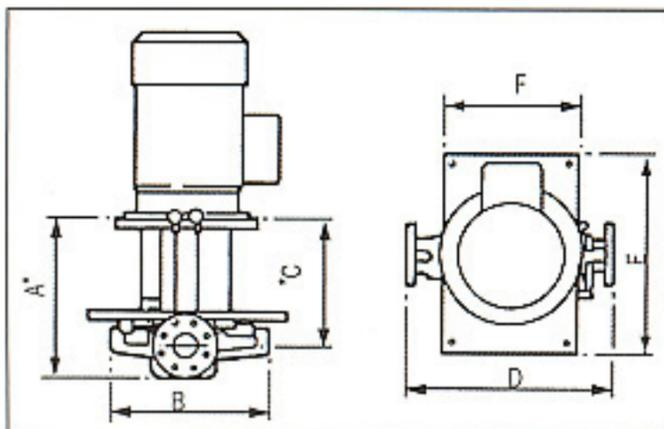
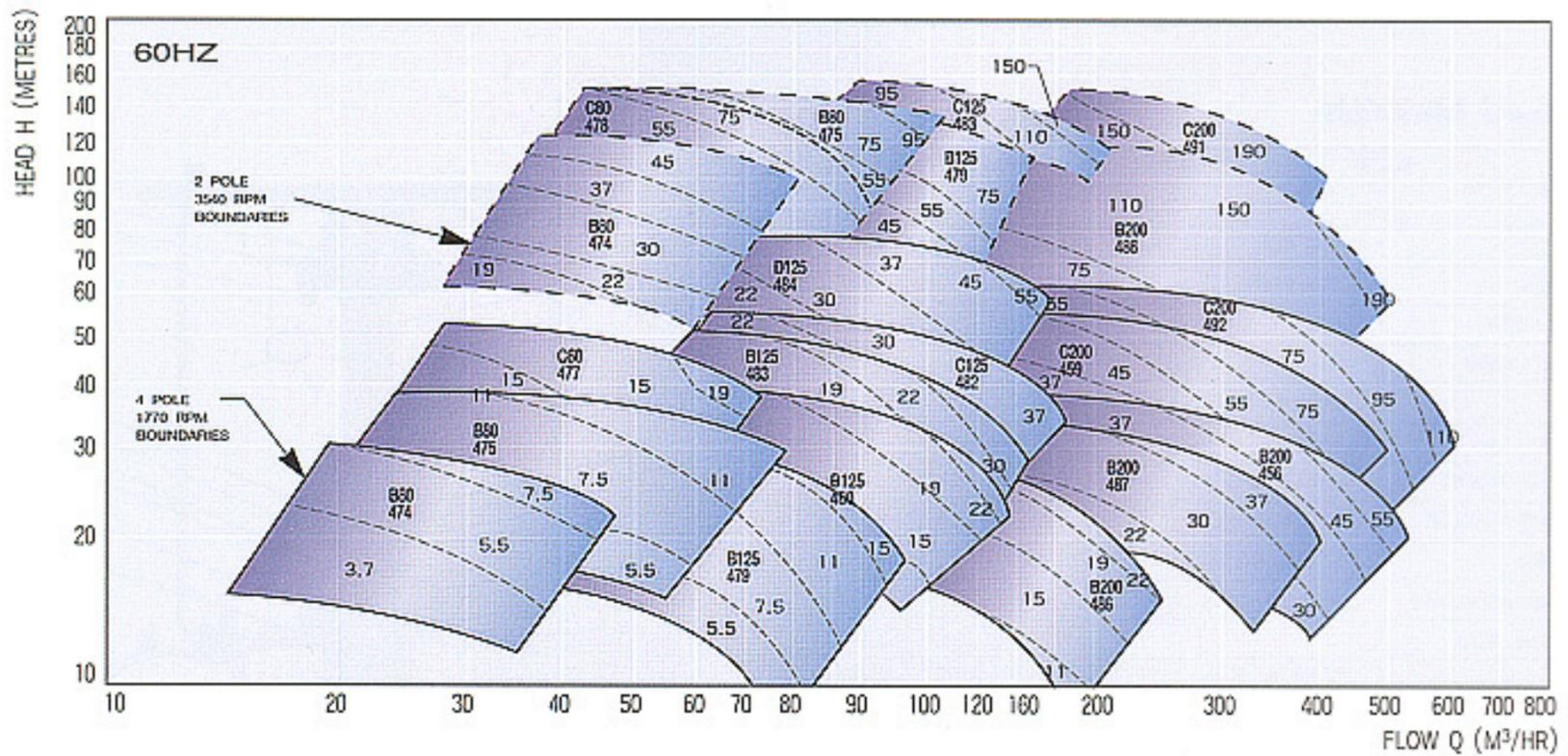
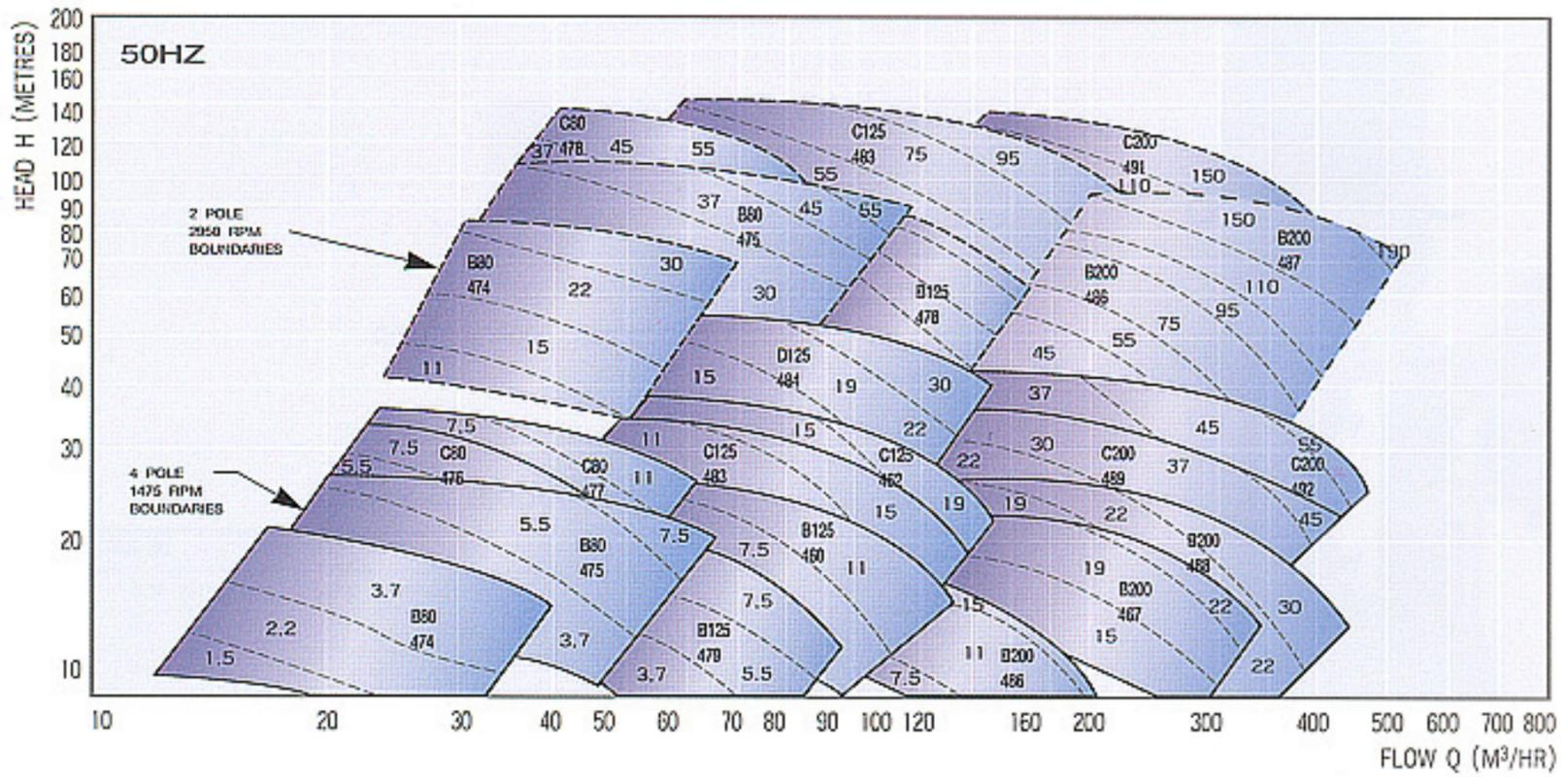

■ Dimensions For Single Suction Pumps

Part No. Type	Dimensions (mm)						
	A	B	C	D	E	F	G
B80	714	580	584	580	554	450	26
C80	314	640	586	640	634	540	26
B125	764	580	609	640	554	450	26
C125	764	660	609	720	634	540	26
D125	764	710	596	760	684	590	26
B200	854	686	671	760	704	540	46
C200	854	686	671	800	704	540	46

■ Stuffing Box Seal

The stuffing box is fitted with mechanical seal only

Fitted with mechanical Seal

Flushing water is led to the stuffing box from the discharge side, and returned to the suction side in casing after flushing mechanical seal

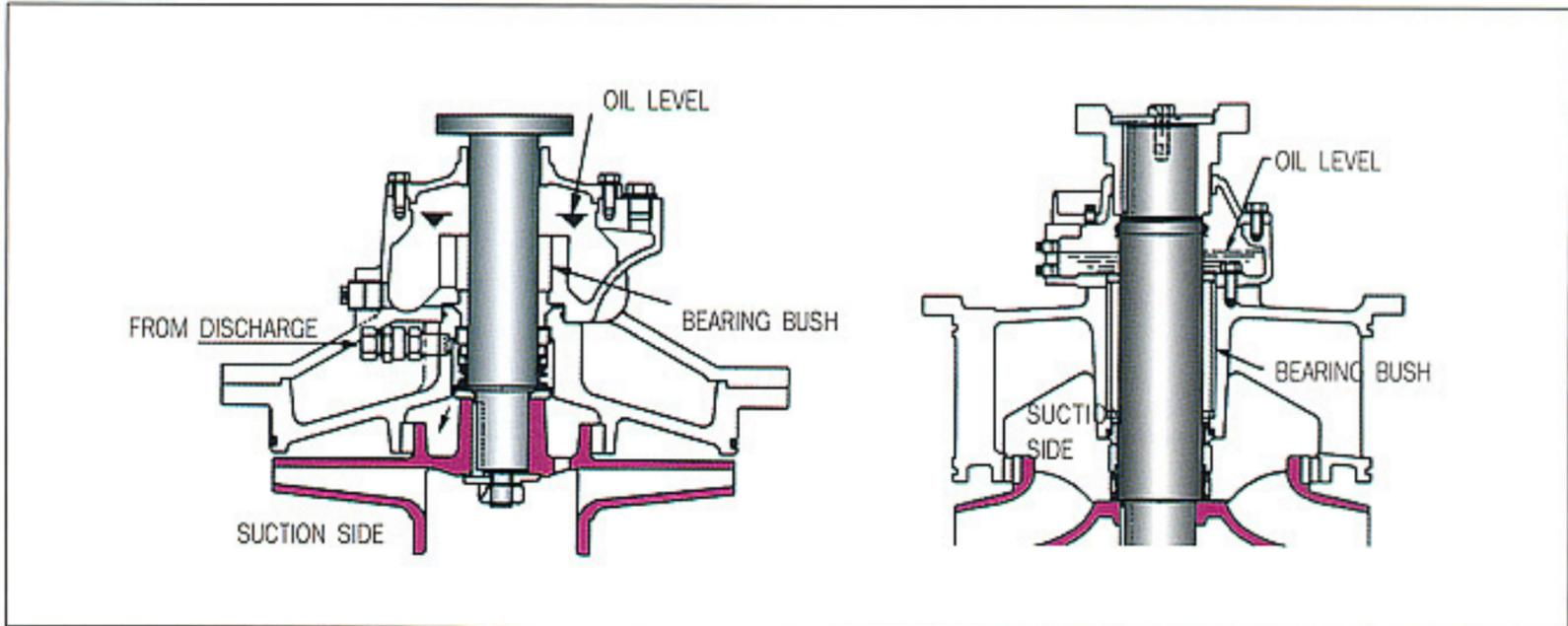

■ Priming unit

When self priming is required, Air Ejector Primer or Liquid Ring Primer(LRP) is available

Liquid Ring Primer can be driven by belt connected with main pump shaft or a separately mounted motor.

A guidance for selection of primer is as follows.

Item	Model	B/C80	B/C/D125	B/C200	DB250	DB300	DB350	DB400	DB500
Air Ejector Primer	KAEI, KAEII	○	○	○	○	○	○	○	
Liquid Ring Primer driven by pump shaft	LRP50B	○	○	○	○				
Liquid Ring Primer driven by separate motor	LRP50M/100M	○	○	○	○	○	○	○	○

* For the detail description of each primer, refer to the primer leaflet.

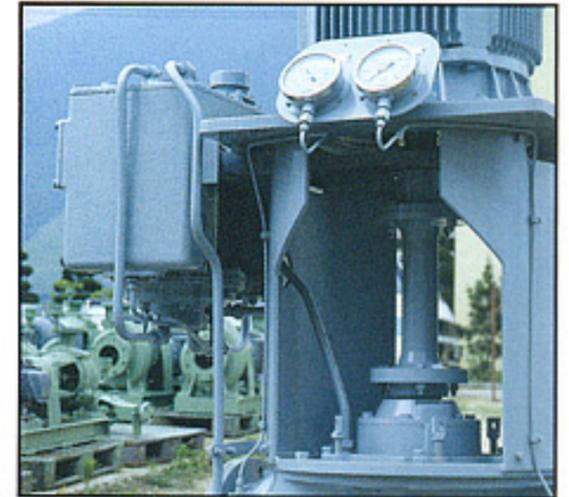

■ Motor

The motor for this type of pump must satisfy the following conditions:

Axial thrust

The thrust due to the weight of the rotating element acts downward.

The maximum values are as shown in the following table.

Unit: Kg

Model	VIB												
	B80	C80	B125	C125	D125	B200	C200	DB250	DB300	DB350	DB400	DB500	2C150
Thrust	34	38	49	58	52	70	83	50	80	100	-	-	80

- Notes**
- The thrust for DB400/500 pumps are variable according to the hydraulic force acting on the impeller.
 - The thrust bearing for the motor must be of the fixed type(below 0.7mm) for up and down directions.
 - The permissible value of elongation of the shaft end due to thermal expansion is to be less than 1mm.

**Screw at the motor shaft end
(Bolt for fixing is supplied by Shin Shin)**

In order to support the pump rotating element the shaft end must be provided with threaded hole for fitting the motor coupling.

Rectangularity and eccentricity for motor flange

The rectangularity of the flange face relative to the axis and the eccentricity of the flange fitting outside diameter must be less than 0.127mm when read from a dial indicator.

Shaft end deflection

The shaft end deflection must be less than 0.05mm when read from a dial indicator.

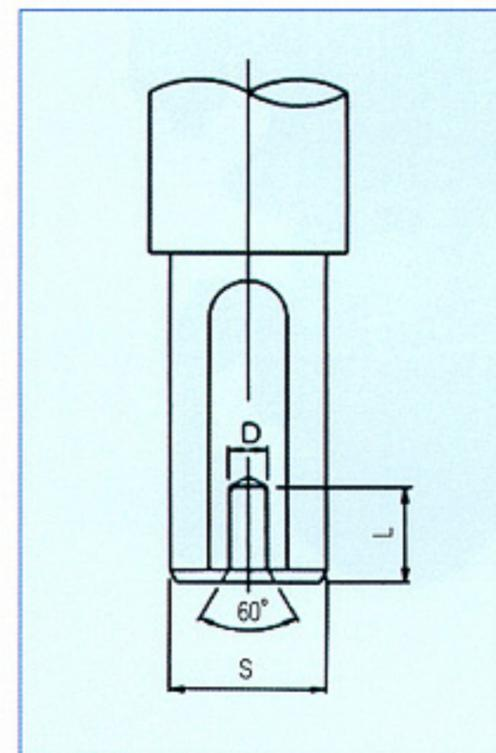

Unit:mm

Motor Shaft(S)	D	Lmin
~38(7.5KW)	M12	22
~48(22KW)	M16	22
~85(150KW)	M16	22

■ **Standard Accessories**

Discharge pressure gauge	1
Suction compound gauge	1
Gauge board	1
Gauge root valve	2
Sealing pipe	1 set
Vacuum unit(for self priming pump)	1 set

■ **Standard Spare Parts**

- 1 pump set of the following spare is supplied for 1ship.
- Gland packing or mechanical seal
 - Coupling bolt & nut
 - Bearing bush
 - Complete set of rotating element(if required)



Homepage : <http://www.sspump.com>

E-mail : sales@sspump.com

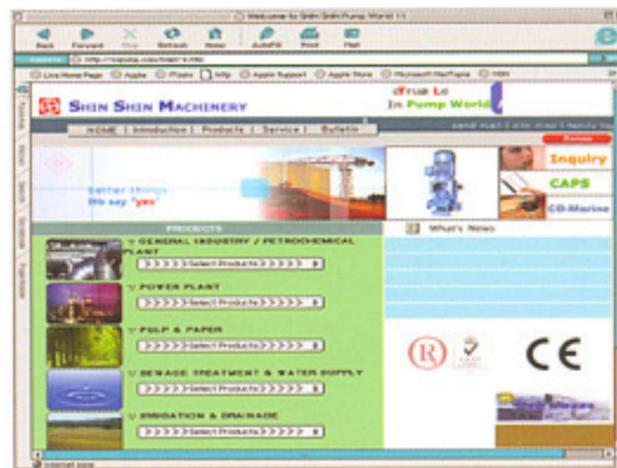

SHIN SHIN MACHINERY CO., LTD.

Head Office & Factory

940-13 Yerim-ri, Chongwan-Myen, Gijang-Gun, Pusan, Korea.

Phone : (051) 727-5300~4

Telefax: (051) 727-5305~8

Seoul Office

Phone : +82-2-752-8419/8403, 778-8832

Telefax: -82-2-755-3156