

CENTRIFUGAL PUMP

ESC

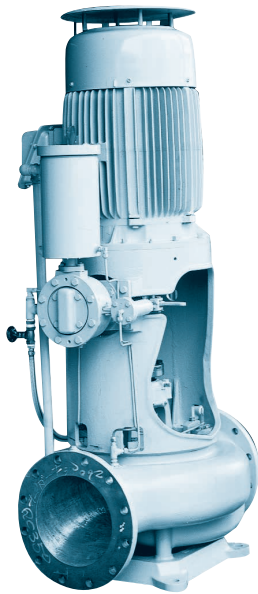

Application

Cooling Fresh Water Pump
Cooling Sea Water Pump
Sea Water Service Pump

Feature

Vertical Single-stage Single-suction
Spacer Coupling Type

Structure & Material

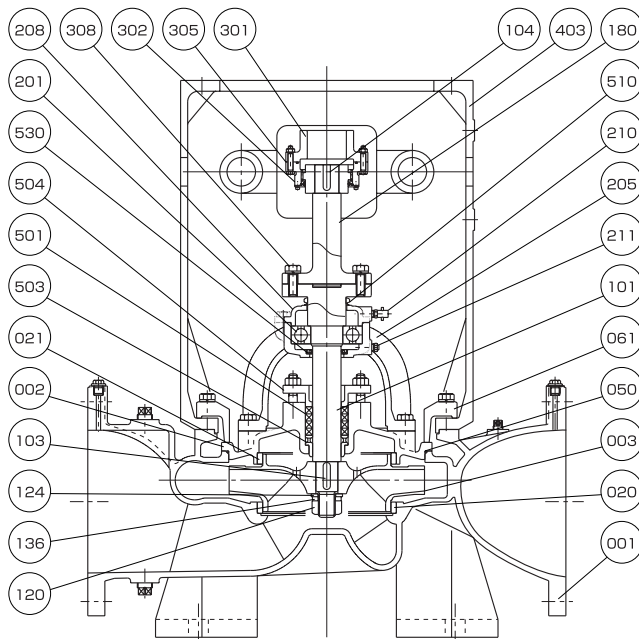

Part No.	Name	Req. No.	Sea Water		Fresh Water	
			Material	JIS	Material	JIS
001	CASING	1	BRONZE	CAC402	CAST IRON	FC200
002	CASING COVER	1	BRONZE	CAC402	CAST IRON	FC200
003	IMPELLER	1	PHOSPHOR BRONZE	CAC502A	PHOSPHOR BRONZE	CAC502A
020	CASING RING	1	BRONZE	CAC402	BRONZE	CAC402
021	CASING RING	1	BRONZE	CAC402	BRONZE	CAC402
050	O-RING	1	RUBBER	NBR	RUBBER	NBR
061	FIXING PLATE	8	MILD STEEL	SS400	MILD STEEL	SS400
101	SHAFT	1	STAINLESS STEEL	SUS304	STAINLESS STEEL	SUS304
103	KEY	1	STAINLESS STEEL	SUS304	STAINLESS STEEL	SUS304
104	KEY	1	CARBON STEEL	S45C	CARBON STEEL	S45C
120	IMPELLER NUT	1	STAINLESS STEEL	SUS304	STAINLESS STEEL	SUS304
124	IMPELLER WASHER	1	STAINLESS STEEL	SUS304	STAINLESS STEEL	SUS304
136	SPRING WASHER	1	STAINLESS STEEL	SUS304	STAINLESS STEEL	SUS304
180	COUPLING SPACER	1	CARBON STEEL	S45C	CARBON STEEL	S45C
201	BALL BEARING	1	BEARING STEEL	SUJ2	BEARING STEEL	SUJ2

Part No.	Name	Req. No.	Sea Water		Fresh Water	
			Material	JIS	Material	JIS
205	BEARING HOUSING	1	CAST IRON	FC200	CAST IRON	FC200
208	BEARING COVER	1	CAST IRON	FC200	CAST IRON	FC200
210	GREASE NIPPLE	1	BRASS	C3602	BRASS	C3602
211	GREASE FITTING	1	BRASS	C3602	BRASS	C3602
301	COUPLING	1	CARBON STEEL	S45C	CARBON STEEL	S45C
302	COUPLING	1	CARBON STEEL	S45C	CARBON STEEL	S45C
305	COUPLING BOLT & NUT	4	Cr-Mo STEEL	SCM435	Cr-Mo STEEL	SCM435
308	BOLT	4	Cr-Mo STEEL	SCM435	Cr-Mo STEEL	SCM435
403	FRAME	1	CAST IRON	FC200	CAST IRON	FC200
501	GLAND PACKING	4	CARBONIZED FIBER	-	CARBONIZED FIBER	-
503	LANTERN RING	1	BRONZE	CAC402	BRONZE	CAC402
504	GLAND	1	BRONZE	CAC402	BRONZE	CAC402
510	V-RING	1	RUBBER	NBR	RUBBER	NBR
530	OIL SEAL	1	RUBBER	NBR	RUBBER	NBR

Performance

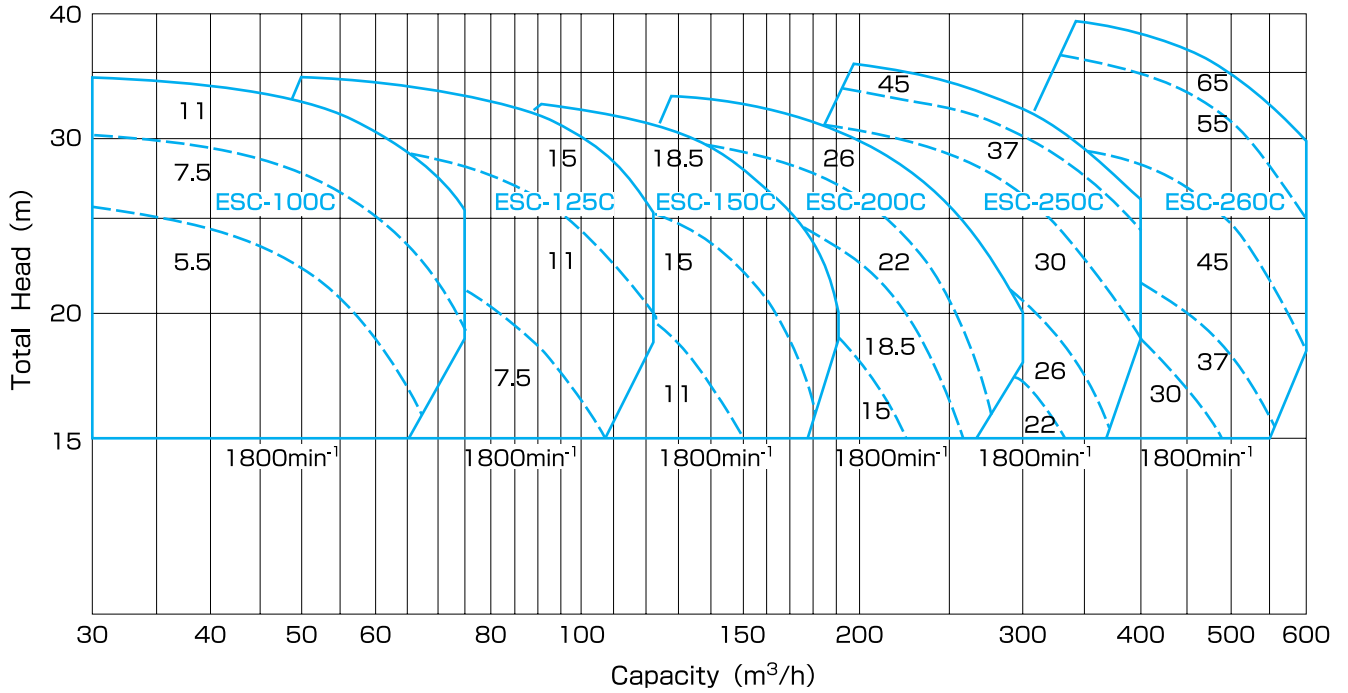

Dimension

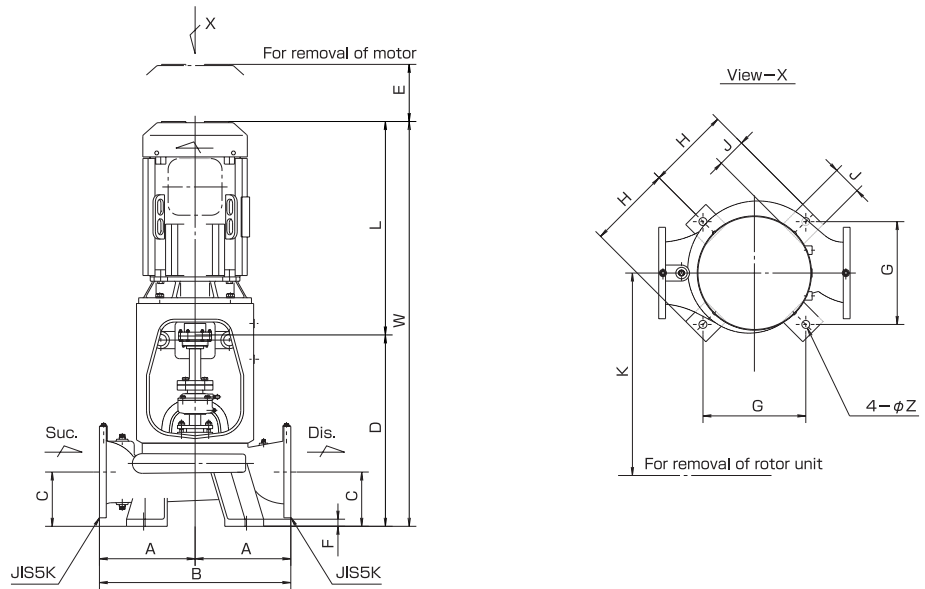

Model No.	Motor		Bore		Dimension (mm)												
	kW	min ⁻¹	Suc.	Dis.	A	B	C	D	E	F	G	H	J	K	L	W	Z
ESC-100C	5.5	1800	100	100	280	560	150	612	150	25	290	240	100	600	480	1092	28
	7.5								200								
	11								200								
ESC-125C	7.5	1800	125	125	300	600	160	622	150	25	290	240	100	600	480	1102	28
	11								200								
	15								200								
ESC-150C	11	1800	150	150	315	630	160	645	200	25	360	290	100	600	635	1257	28
	15								200								
	18.5								200								
ESC-200C	15	1800	200	200	335	670	190	670	200	25	360	290	100	600	685	1330	28
	18.5								200								
	22								200								
	26								200								
ESC-250C	22	1800	250	250	400	800	220	790	200	25	410	325	100	700	725	1395	28
	26								250								
	30								250								
	37								250								
ESC-260C	30	1800	250	250	400	800	220	820	200	25	410	325	100	700	725	1545	28
	37								250								
	45								250								
	55								250								
	65								250								